

125T-15A FASTER 125

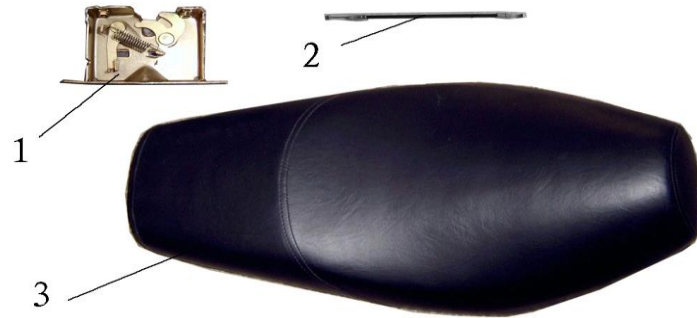

F-1 座垫总成  
(Seat cushion)



1	150T-5A(1)-030700	Seat lock bracket	1
2	150T-5A(1)-030701	Seat lock cable	1
3	150T-5A(1)-002000	Seat groupware	1

F-2 工具箱  
(Tool box)

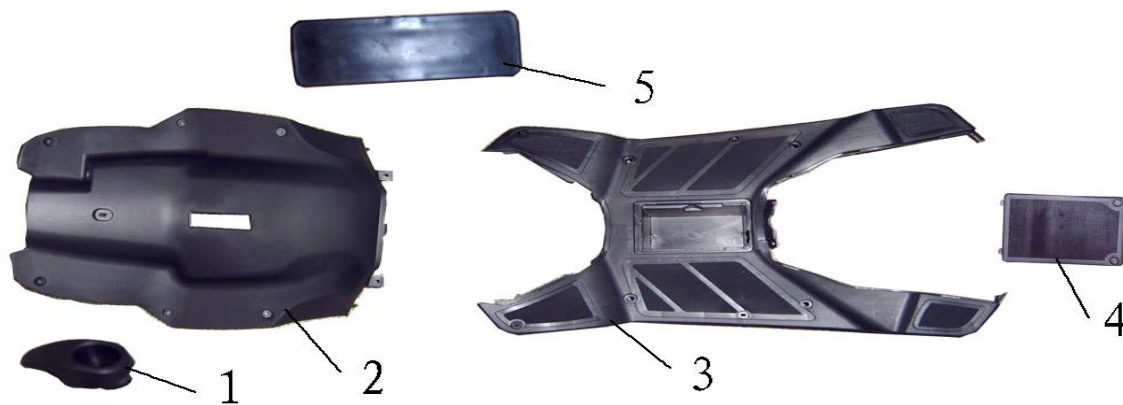

1	150T-5A(1)-050403	Motorcycle safety helmet pothook	1
2	150T-5A(1)-050401	Luggage box	1
3	150T-5A(1)-050501	Foot plate	1
4	150T-5A(1)-050502	Cover ,battery	1
5	150T-5A(1)-050402	Number cover	1

F-3 杂物箱



1	150T-5A(1)-050002	Cap, luggage box	1
2	150T-5A(1)-050001	Front cover of luggage box	1
3	150T-5A(1)-050003	Front cover of luggage box	1
4	150T-5A(1)-050004	luggage box front small cover	1

F-4 前大板

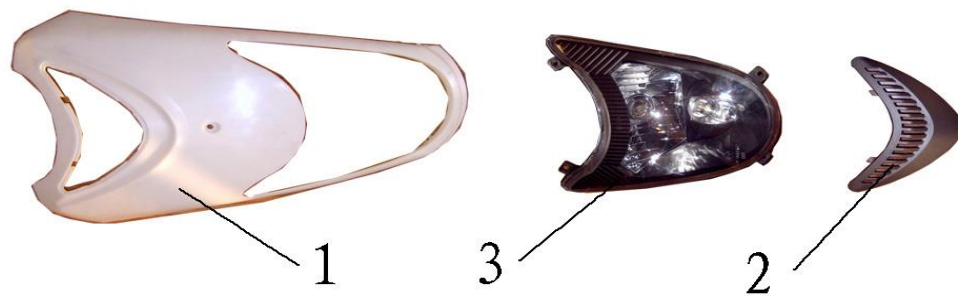

1	150T-5A(1)-050101A	Front board	1
2	150T-5A(1)-050102A	Front board decorate piece	1
3	150T-5A(1)-050200A	Font headlight	1

F-5 燃油箱总成

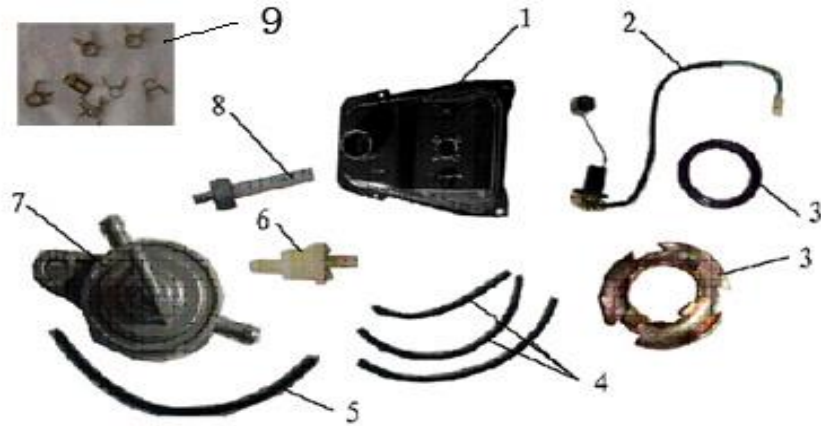

1	150T-5A(1)-060100	Fuel tank	1
2	150T-5A(1)-060101	Oil digit sensor	1
3	150T-5A(1)-060102	Sensor press board and airproof circle	各1
4	150T-5A(1)-060601	Gasoline pipe	3
5	150T-5A(1)-060603	Pressure pipe	1
6	150T-5A(1)-060106	filter	1
7	150T-5A(1)-060104	Self-priming switch	1
8	150T-5A(1)-060103	Filter web mouth	1
9	150T-5A(1)-060002	block spring	6

F-6 装饰板

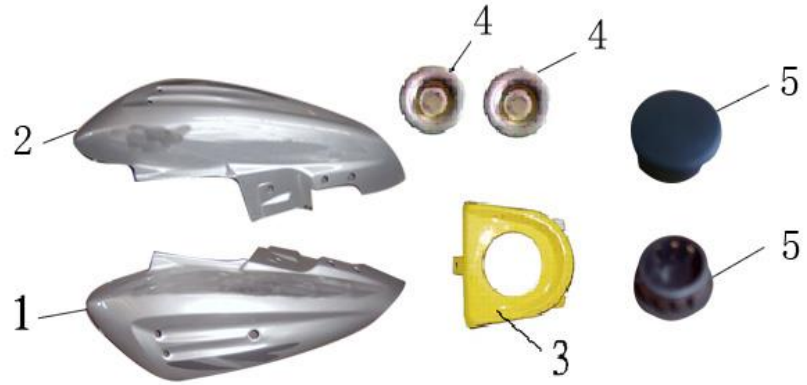

1	150T-5A(1)-050301	L body side cover	1
2	150T-5A(1)-050302	R body side cover	1
3	150T-5A(1)-050005	Add oil cover	1
4	150T-5A(1)-040010	Decorate board mat	2
5	150T-5A(1)-090010.1	Decorate board rubber mat	2

F-7 左右护板

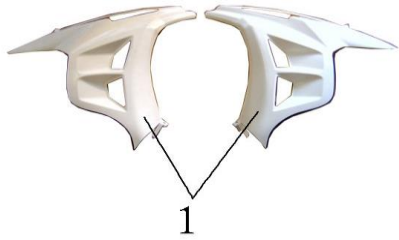

1	150T-5A(1)-050202A	L and R protect board( I )	1副
2	150T-5A(1)-050203A	L and R protect board( II )	1副
3	150T-5A(1)-050201A	L and R turning light	1副



F-8 后尾板组件



1	150T-5A(1)-050703	L and R back turning light	各1
2	150T-5A(1)-050702	License plate bracket	1
3	150T-5A(1)-050701	Tail board	1
4	150T-5A(1)-050800	Taillight groupware	1

F-9 后扶手



1	150T-5A(1)-003000	Back armrest	1
2	GB70-93	M8X35 inner six corner bolt	2

F-10 电瓶

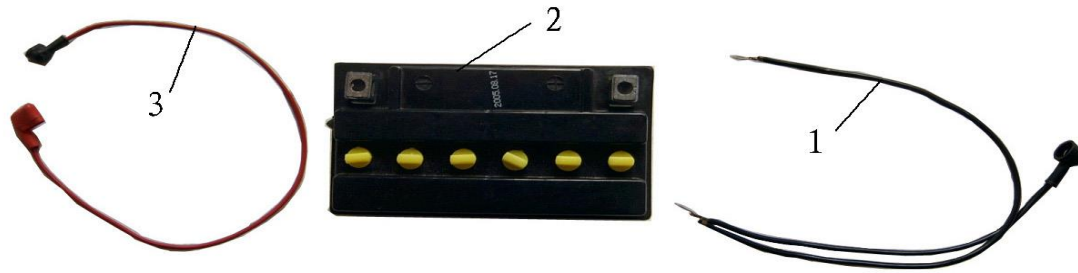

1	150T-5A(1)-070005	Cathode cable	1
2	150T-5A(1)-070400	Battery	1
3	150T-5A(1)-070006	Anode cable	1

F-11 主电缆  
(Wire harness)



1	150T-5A(1)-070100	Start-up relay	1
2	150T-5A(1)-070200	Ignition loop	1
3	150T-5A(1)-070300	horn	1
4	150T-5A(1)-070001	cable	1
5	150T-5A(1)-070002	ignition	1
6	150T-5A(1)-070003	flasher	1
7	150T-5A(1)-070004	manostat	1
8	150T-5A(1)-070007	resistance	1
9	150T-5A(1)-070301	electricity door lock	1套
10	150T-5A(1)-090020	wrap	

F-12 前轮

Rear wheel

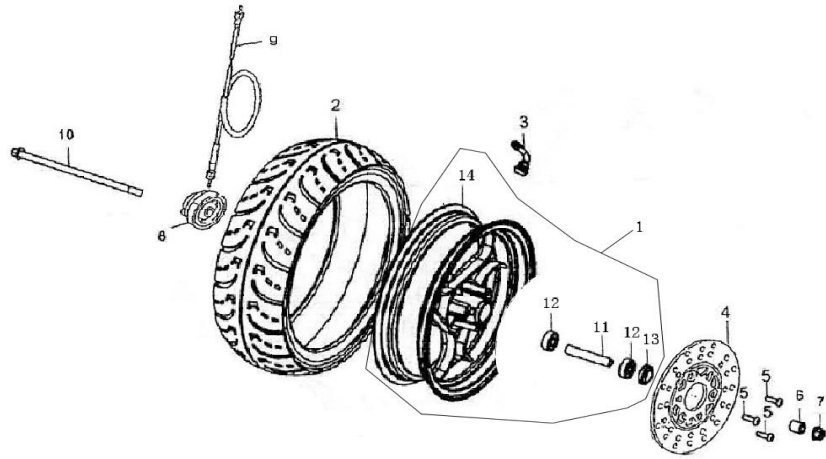

1	150T-5A(1)-010201	Front wheel assy	1
2	150T-5A(1)-010202	Vacual tire	1
3	150T-5A(1)-010203	Value mouth	3
4	150T-5A(1)-010204	Disc brake plate	1
5	150T-5A(1)-010205	Disc brake plate bolt	1
6	150T-5A(1)-010001	Front-wheel drive axle	1
7	GB6177-86	M12X1.25 locknut	1
8	150T-5A(1)-010400	driver	1
9	150T-5A(1)-020203	Odometer gentle axis	2
10	150T-5A(1)-010001	Front axle	1
11	150T-5A(1)-010201.1	Collar Fr.axle cistance	1
12	GB278-82	Bearing racial ball	
13	150T-5A(1)-010201.2	Dust seal	
14	150T-5A(1)-010201.3	front-wheel hub	

F-13 后轮  
Rear wheel

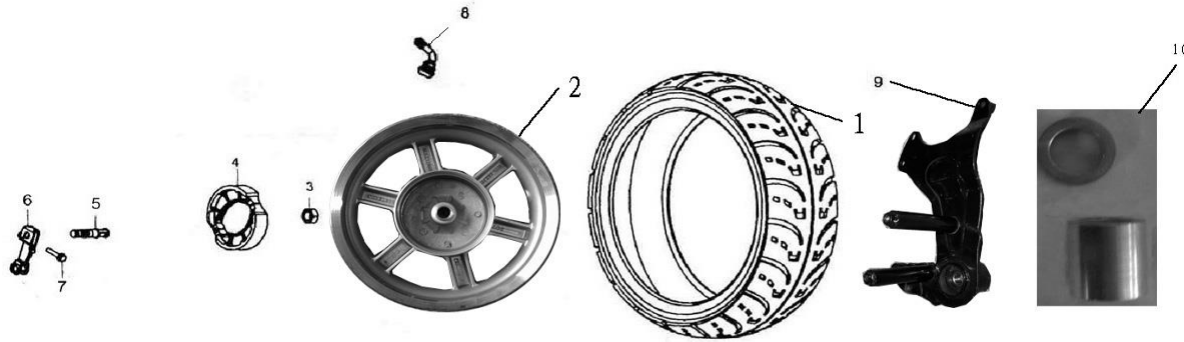

1	150T-5A(1)-040600	Vacual tire	5	1
2	150T-5A(1)-040500	back al wheel		1
3	GB6184-86	Inner six corner blot M16X1.5		1
4	150T-5A(1)-040005	Hoof block assembly		1
5	150T-5A(1)-040003	Back apply the brake rocker axis		1
6	150T-5A(1)-040004	Back apply the brake rocker		1
7	GB5787-86	Inner six corner blot M8X35		5
8	150T-5A(1)-010203	Value mouth		各1
9	150T-5A(1)-040700	Triangle unite board		
10	150T-5A(1)-040006	Rear wheel bush(long, short)		

F-14仪表组合

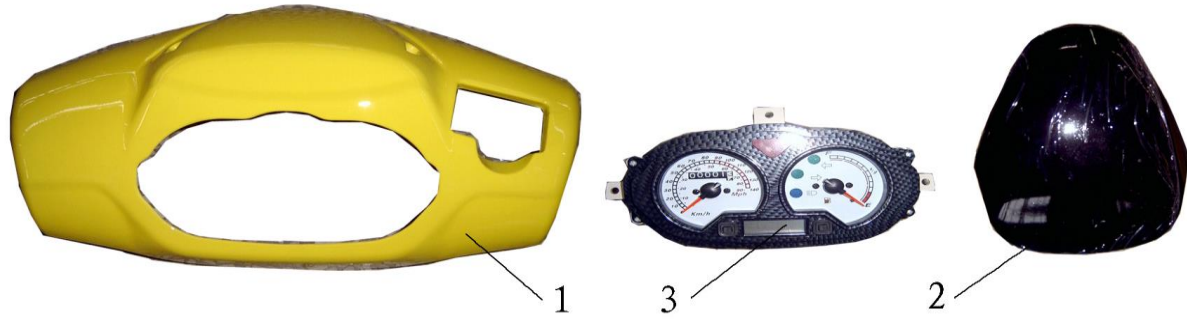

1	150T-5A(1)-020202	speedometer cover	1
2	150T-5A(1)-020203	Speedometer block sunshine cover	10
<b>3</b>	<b>150T-5A(1)-020204</b>	<b>speedometer groupware</b>	<b>10</b>

F-15方向把总成



			数量
1	150T-5A(1)-001000	L and R rearview moirror	1
2	150T-5A(1)-020101	L and R handle glove	1
3	150T-5A(1)-020102	L combination switch	1
4	150T-5A(1)-020201	Speedometer below cover	1
5	150T-5A(1)-020105	R combination switch	1
6	150T-5A(1)-020104	Steering handle	30
7	150T-5A(1)-020103	Back apply the brake haul cable	
8	150T-5A(1)-020106	Accelerograph haul cable	



F-16前制动主油缸

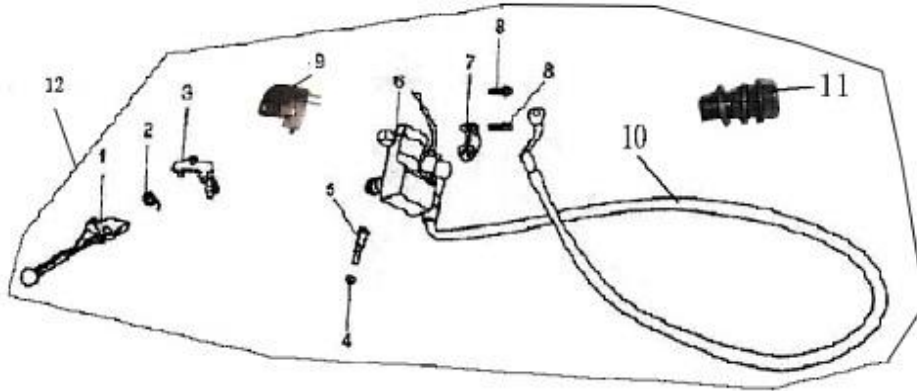

			1
			1
1	150T-5A(1)-010301.1	Grip comp handle R	1
2	150T-5A(1)-010301.2	Returning spring	1
3	150T-5A(1)-010301.3	Connecting socket	1
4	150T-5A(1)-010301.4	Nut M5	1
5	150T-5A(1)-010301.5	Bolt comp handle R	1
6	150T-5A(1)-010301.6	Oil cylinder ,Fr brake comp	2
7	150T-5A(1)-010301.7	Semicircle cap	1
8	150T-5A(1)-010301.8	Bolt M6X22	1
9	150T-5A(1)-010301.9	Switch, front stop	1
10	150T-5A(1)-010301.10	oil pipe	1
11	150T-5A(1)-010301.11	bolt,oil inlet	
12	150T-5A(1)-010301	Fr disc brake pump	

F-17 前制动副油缸

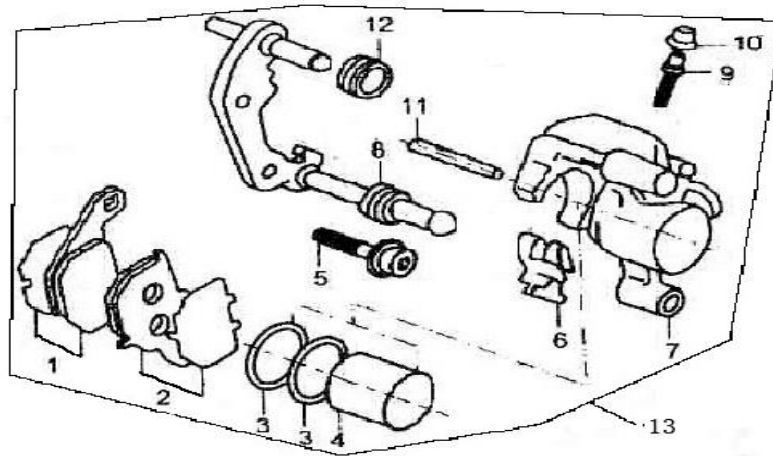

			2
			2
1(2)	150T-5A(1)-010302.1	Disc brake piece	1
3	150T-5A(1)-010302.2	Oil seal	1
4	150T-5A(1)-010302.3	piston	1
5	150T-5A(1)-010302.4	Apply the brake clamp bolt	1
6	150T-5A(1)-010302.5	shrapnel	1
7	150T-5A(1)-010302.6	Assistant cylinder	1
8	150T-5A(1)-010302.7	insulator	1
9	150T-5A(1)-010302.8	Exhaust bolt	1
10	150T-5A(1)-010302.9	cover	1
11	150T-5A(1)-010302.10	pin	1
12	150T-5A(1)-010302.11	Protect cover	
13	150T-5A(1)-010302	Fr disc brake pump	

F-18 发动机·附件

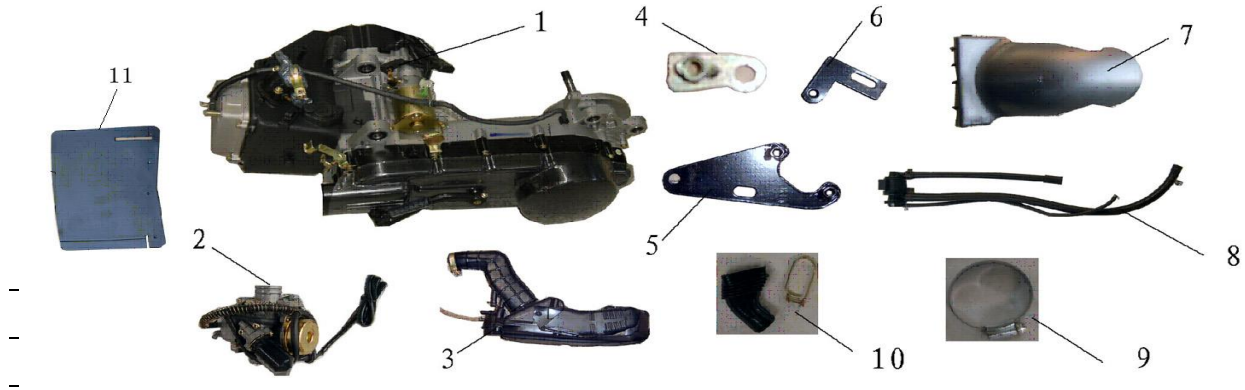

			1
1	125T-15-040100	engine	10
2	125T-15-040200	carburetor	1
3	125T-15-040400	Air filter groupware	5
4	150T-5A(1)-040009	Air filter frame	1
5	150T-5A(1)-040007	Rr wheel fender frame(big)	1
6	150T-5A(1)-040008	Rr wheel fender frame(small)	1套
7	150T-5A(1)-040011	Rr wheel fender	1
8	150T-5A(1)-040013	Twice burning unilateralism valve	1套
9	150T-5A(1)-040002	Air cleaner holder, air pipe	1
10	150T-5A(1)-040012	ventilate pipe groupware	
11	150T-5A(1)-040016	block water rubber skin	

F-19后减震器

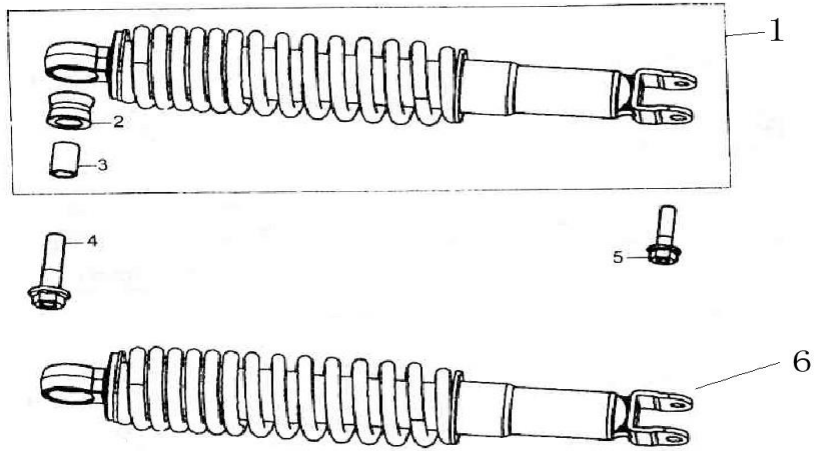

			1
1	150T-5A(1)-040301	L Rr Cushion assy	1
2	150T-5A(1)-040301.1	Bush rubber	1
3	150T-5A(1)-040301.2	Collar rubber	1
4	GB5787-86	Bolt flange M10X1.25X40	1
5	GB5787-86	Bolt flange M8X30	
6	150T-5A(1)-040302	R Rr Cushion assy	

F-20下联板组件

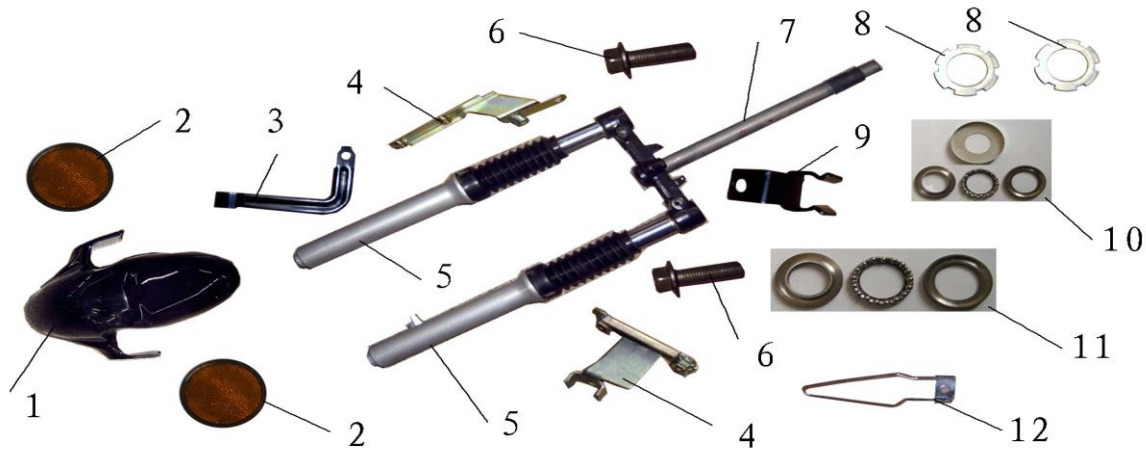

1	150T-5A(1)-010003	Front wheel fender 3	2
2	150T-5A(1)-010005	L and R side reflector implement	1
3	150T-5A(1)-010008	Disc brake pump vitta thread nip ( I )	2
4	150T-5A(1)-010006	Front wheel fender bracket	2
5	150T-5A(1)-010102	Front absorber	1
6	GB5787-86	M10X38 six corner bolt	2
7	150T-5A(1)-010101	Lower connection board	1
8	150T-5A(1)-000003	Compaction nut	1套
9	150T-5A(1)-010009	Disc brake pump vitta thread nip ( II )	1套
10	150T-5A(1)-000001	Upper axletree groupware	1
11	150T-5A(1)-000002	Lower axletree groupware	
12	150T-5A(1)-010007	Odograph soft axes nip	

F-21 消声器

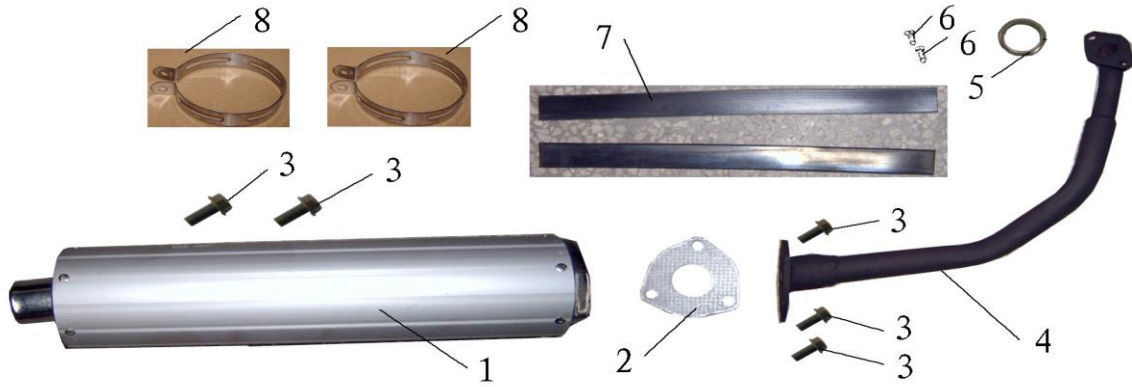

1	125T-15-040801	muffler	1
2	150T-5A(1)-040803	Vent-pipe heat insulation mat	5
3	GB5787-86	M8X25 six corner bolt	1
4	125T-15-040802	Vent-pipe	2
5	150T-5A(1)-040001	Washer	2
6	GB823-86	Cap nut M6	2
7	150T-5A(1)-040015	Muffler block hoop rubber mat	
8	150T-5A(1)-040014	Muffler block hoop	

F-22 支架

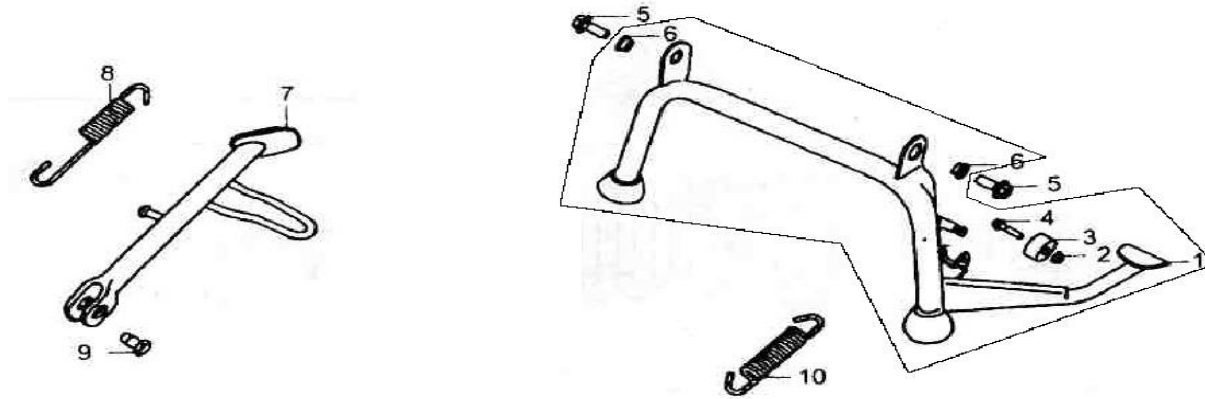

1	150T-5A(1)-030500	Big support groupware	1
2	GB6187-86	Bolt flange M6	1
3	150T-5A(1)-090010.2	Cushion pastern wheel	2
4	GB5787-86	Bolt flange M6X25	2
5	GB5787-86	Bolt flange M10X25	1
6	150T-5A(1)-030005	Big maintain bush	1
7	150T-5A(1)-030400	Single support	1
8	150T-5A(1)-030003	Single support haul spring	1
9	150T-5A(1)-030002	Single support bolt	
10	150T-5A(1)-030005	Big support haul spring	

F-23 车架总成

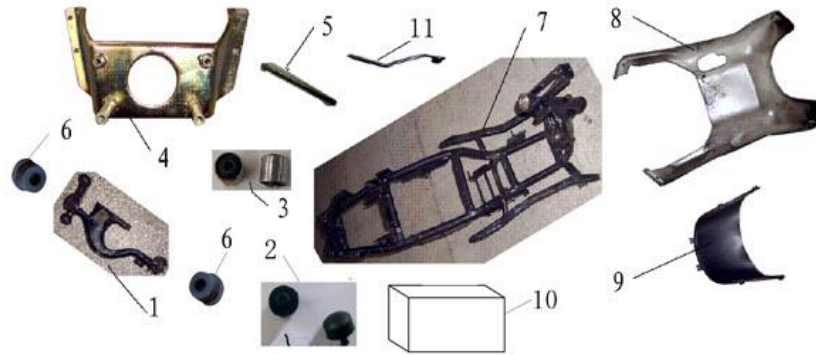

			1
			2
1	150T-5A(1)-030600	Hang frame	2
2	150T-5A(1)-090010.3	hang frame cushion set	1
3	150T-5A(1)-030006	Hang frame bush	1
4	150T-5A(1)-030007	Oil box press board	2
5	150T-5A(1)-000004	Condole frame axes	1副
6	150T-5A(1)-090010.4	Hang frame plug	1
7	150T-5A(1)-030100	frame	1
8	150T-5A(1)-030008	Fender frame	1套
9	150T-5A(1)-030009	Fender frame front	1
10	150T-5A(1)-080000	the whole standard piece	
11	150T-5A(1)-030200	Board bracket	



F-24 随车工具

Tools set

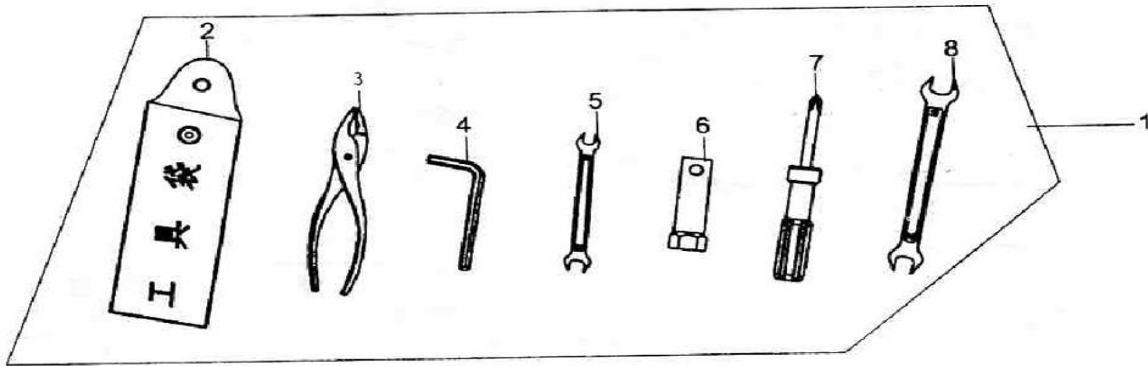

1	150T-5A(1)-090030	Tool comp	1
2	150T-5A(1)-090030.1	Tool bag	1
3	150T-5A(1)-090030.2	Plier 165	1
4	150T-5A(1)-090030.3	Wrench	1
5	150T-5A(1)-090030.4	Wrench 10-12	1
6	150T-5A(1)-090030.5	Collar comp spark plug	1
7	150T-5A(1)-090030.6	Plincers	
8	150T-5A(1)-090030.7	Wrench 12-14	